



Ampair has been manufacturing high quality renewable energy power systems in the UK for nearly forty years. Ampair turbines are renowned internationally for their durability in extreme environments. With nearly 30,000 systems sold to date, our turbines and power systems are currently providing power to equipment in virtually every country and ocean on the globe.

Ampair supplies power solutions to ZephIR® deployment sites with many different underlying social/economic issues which effect the cost of project implementation. For this reason we can in addition to our off the shelf solutions provide custom power solutions so that, wherever in the world you deploy your equipment, there is an Ampair packaged power solution that fits the bill.



Ampair Energy Ltd  
2 Milborne Business Centre  
Milborne St Andrew  
Dorset  
United Kingdom DT11 0HZ

Tel +44 (0) 1258 837 266  
Email [zephir@ampair.com](mailto:zephir@ampair.com)

[ampair.com](http://ampair.com)



ZephIR c/o Natural Power  
The Old Barns  
Fairoaks Farm  
Hollybush, Nr Ledbury  
United Kingdom HR8 1EU

Tel +44 (0) 1531 650 757  
Email [zephir@yourwindlidar.com](mailto:zephir@yourwindlidar.com)

[yourwindlidar.com](http://yourwindlidar.com)

©Ampair 2011 Ampair® is a registered trademark of Ampair Energy Ltd

# Packaged Power



# Packaged Power

Ampair has been manufacturing high quality renewable energy power systems in the UK for nearly forty years. Ampair turbines are renowned internationally for their durability in extreme environments. With nearly 30,000 systems sold to date, our turbines and power systems are currently providing power to equipment in virtually every country and ocean on the globe.

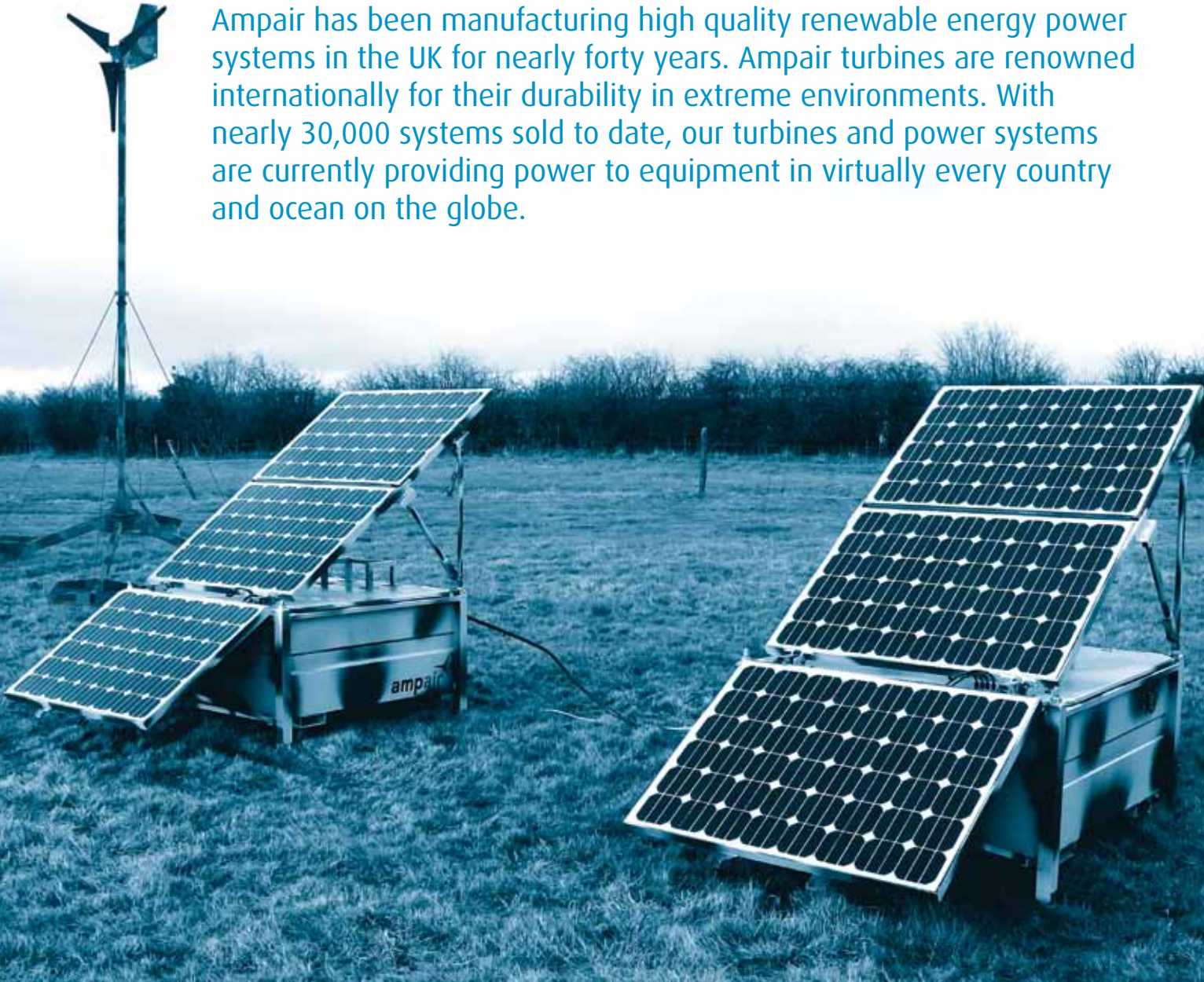

## Unattended Reliability

In recent years, Ampair has worked closely with renewable energy consultancy, Natural Power, to develop the 'packaged power' range of renewable energy power systems to power ZephIR® wind lidar units. During this time, we have proven that it is possible to power this equipment reliably with a range of easy to deploy, renewables powered

systems that vastly reduce the running costs associated with traditional remote site power supplies. Whether your requirement is for an onshore, offshore, desert or arctic deployment, we have a packaged power system that will power your equipment reliably - year round.

## Cost Reductions

The use of Ampair package power systems negates the need for refuelling costs such that engineers only have to visit the site to relocate the equipment.

### 100% availability is key

Ampair uses its proprietary proAmpair™ software to ensure that the system is correctly specified to meet your application.

### Zero maintenance

With an Ampair system you should only need to visit the site in order to relocate the equipment, refuelling visits are a thing of the past.

### Easy deployment

Available as trailerPods for sites with 4x4 or road access or as helicopter deployable heliPods for sites with more challenging access. We design the systems to be one man deployable and to be towed by typical vehicle fleet.

### Hybrid systems

Where solar PV and wind generation needs to be supplemented, Ampair provides both fuel cell and diesel back up options to ensure continuous operation until the next redeployment.

### Reliable generation

The Ampair 600 wind turbine continually wins 'best in class' awards and its rugged construction and strong power curve ensure a good level of charge is maintained even in the harshest of environments.

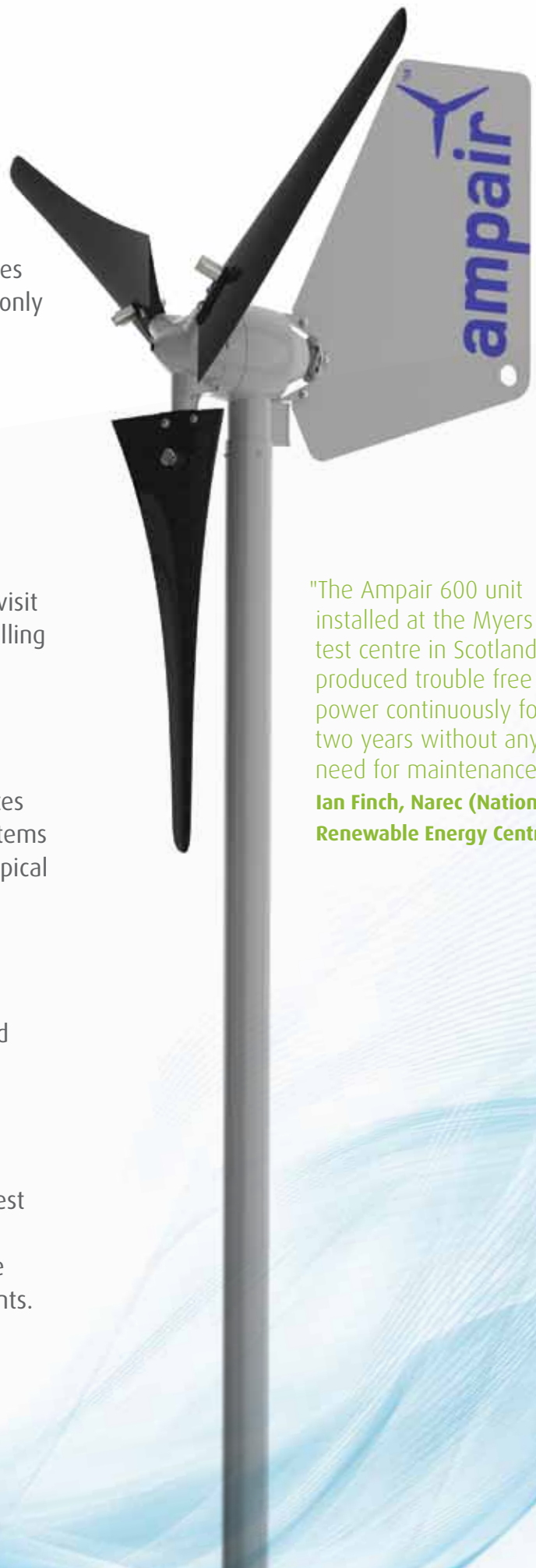

"The Ampair 600 unit installed at the Myers Hill test centre in Scotland produced trouble free power continuously for two years without any need for maintenance"

**Ian Finch, Narec (National Renewable Energy Centre)**

# System Sizing

Specifying the right balance of battery capacity, solar panels and wind turbines on each Ampair packaged power unit is crucial in maintaining reliable power supply to your equipment. To mitigate this risk, Ampair simulates the performance of each system in its proposed range of deployment locations, ensuring that a system is never under or over specified.

When sizing a system, Ampair uses its industry leading simulation software proAmpair™ to give an estimation of annual solar and wind energy yield at 1 hour intervals at 5km grid points. The system also forecasts the days of availability and the depth of discharge in the battery bank. At this level of detail, we can be sure that the system we supply you with will do the job and that the battery bank life will be extended through the minimisation of and reduction in depth of cycling.

We have taken the hard work and risk out of choosing a system. If a system is over specified, the cost and weight of the equipment can be excessive. If a system is undersized, availability of power supply may be jeopardised. Our customers just need to list the potential deployment locations of the equipment and the load required and Ampair will specify the appropriate system.

Security of your asset is also key. Ampair take into account the underlying social/economic issues in your chosen deployment location before recommending a system. In doing so, we may opt to recommend a custom power solution to ensure that your project is successful whilst still delivering the cost benefits of a renewable based power supply.



## Monitoring

All Ampair solutions use the ZephIR's comms link, and with a firmware upgrade, the ZephIR® can be configured to send a warning SMS to Ampair should the power supply voltage drop below our

warning threshold for the system. We then work with our customers to monitor the systems and determine if the unit requires maintenance.

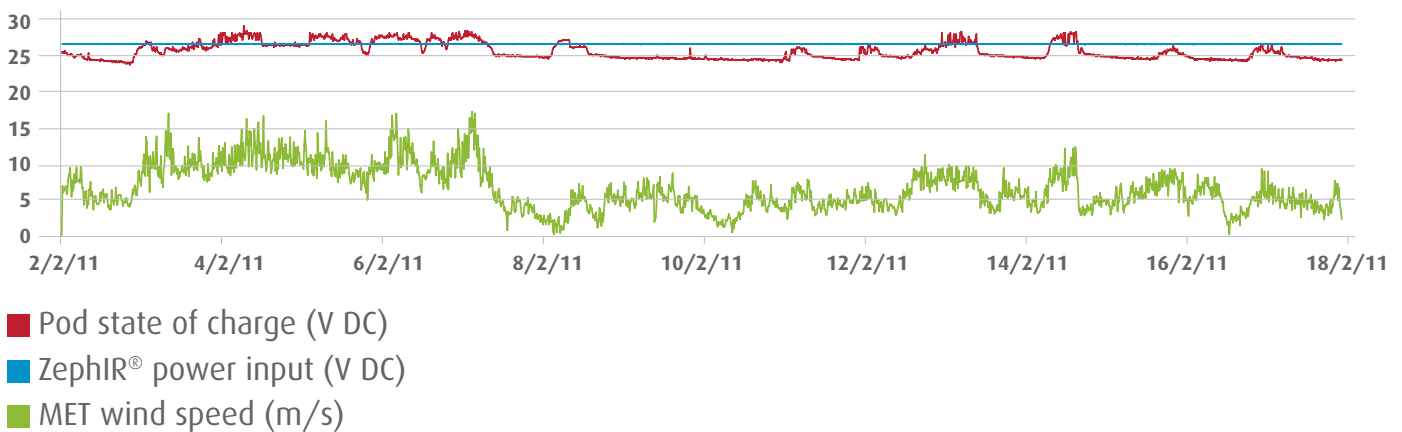

## Warranty & Support

Ampair offers a standard 2 year back to base warranty on all its systems which can be extended. Onsite support is also available for relocations or any logistical requirements.

Please visit the Ampair website to download a copy of our terms and conditions.

## Purchase or Lease

Whether your project requires a power supply for six months or six years, Ampair offers a range of purchase or lease options to fit your requirements.



# heliPods™ HP 1600/2000

The Ampair range of heliPods™ are designed to be used where access is difficult. They can be trailered, heli-lifted or forklifted into position. The pods are designed to fit within the standard international shipping pallet footprint of 1200mm x 1200mm to reduce the cost of international shipping.

The pods are constructed of lightweight Aerospace aluminium construction and can be painted in camouflage to discretely blend into your terrain. As a modular system, multiple pods can be linked for higher loads, the battery size can be increased

to give additional storage or Ampair 600 wind turbines can be added to increase the level of generation. In addition, the pods are available with an internal fuel cell or external diesel back up system.

## Features

- Sturdy wind down legs for easy levelling on slopes of up to 15°
- Heli liftable - pod weight is kept low to facilitate lower cost helicopter rental.
- Easy to deploy fold-out 780W PV array - folds flat for transport.
- Ampair 600 wind turbines supplied on rapid deploy masts.
- Pallet size (1200mm x 1200mm) for shipping on conventional freight.
- Sealed AGM batteries avoids 'hazardous substance' freight issues.
- Can be deployed in and out of optional trailer.
- Integral fuel cell back up option.
- External diesel back up option.

**ZephIR** 300

ZephIR can be deployed up to 100m away from pods

PV array folds flat on top of pod lid



legs are adjustable with 300mm travel

## heliPod™ System - 2 x aluminium battery box

Code	Battery Bank	Turbine (W)	PV (W)	Weight
HP 1600	1600 AH	Max 2 x Ampair 600	780	2 x 400 kg
HP 2000	2000 AH	Max 2 x Ampair 600	780	2 x 480 kg

### Construction

- Alchromed and powder coated aerospace grade aluminium construction.
- IP protected venting.
- Impact protected battery compartment.
- Controls and connectors situated internally.
- Armoured cables.

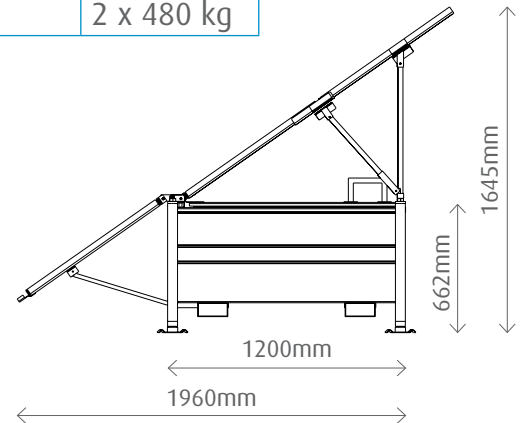

### Options

- fuel cell emergency backup rated at 90W continuous, internally mounted – silent operation.
- 3.5 kVA diesel emergency backup externally mounted.
- Heavy duty double axle trailer with removable lock up canopy, carries 2 x pods + 2 x turbines.
- Lifting gantry to remove pods from trailer on site.

## heliPod™ Rapid Deploy Tower

Code	Tower Components	Weight
RDM-5.5	Ships on 1 x standard pallet + additional pallet with 2 x 2500mm pole sections, or can be shipped in optional heliPod™ trailer	Legs, turbine and hinge plate pallet = 215 kg Tower sections = 67 kg

### Deployment

- Hydraulic tilt up mast for easy one man deployment.
- Feet can be ground anchored, or weighted with locally available material.
- Rated for IEC class 1 windspeeds.

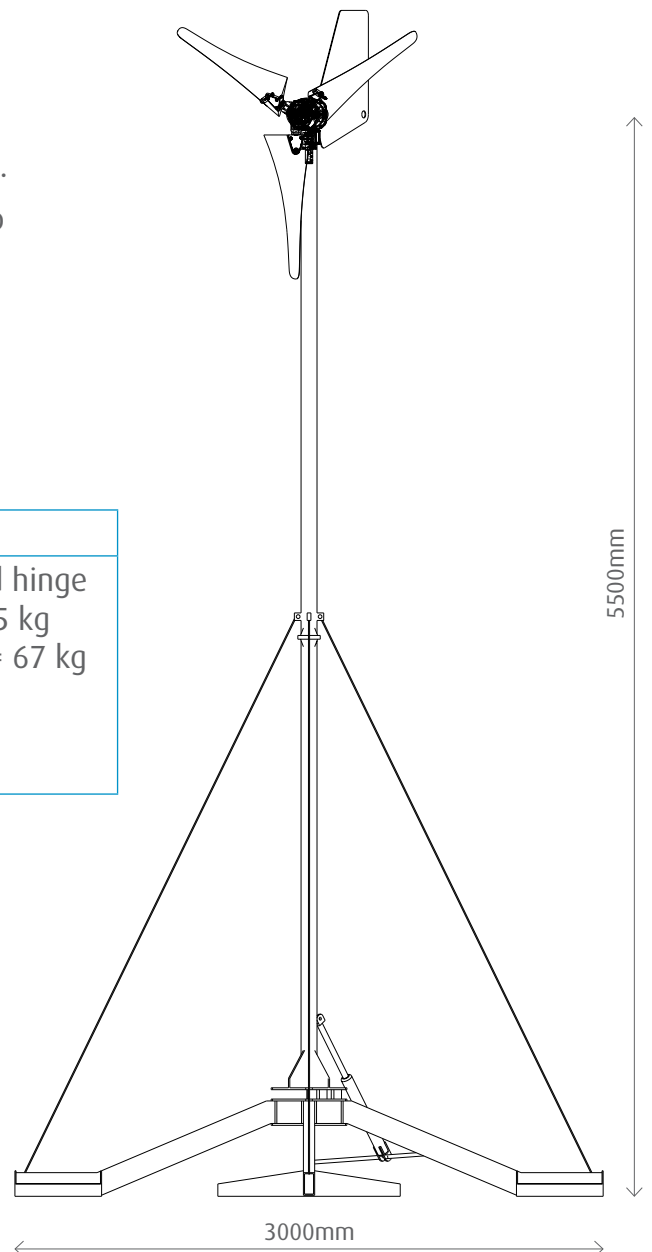

# trailerPods™ - TR 1600/2000/4000

Ampair's TR range of trailerPods™ are effectively the same system as the heliPods™ but have one key difference, the ZephIR® unit is housed inside the trailerPod™.

The trailerPod™ is designed to be used for reasonably flat ground and can be sited on slopes of up to 5% gradient using its jacks.

The trailerPods™ are of rugged design with high ground clearance and can be painted in camouflage to discretely blend into your deployment terrain.

## Features

- 2 x Ampair 600 Watt turbines as standard.
- Electric winches for raising and lowering turbine masts.
- 800 or 1600 Watts of PV options, all on rapid deploy frames.
- Twin roof hatches, one for Lidar & met mast, second for man access.
- High ground clearance off road trailer rated up to 3500kg.
- Hydraulic platform for rapid deployment of ZephIR® through roof aperture.
- Optional internal fuel cell back up system.
- Optional internal diesel back up system.



## trailerPod™

Code	Battery Bank	Turbine (W)	PV (W)	Weight
TR1600 - 8	1600 AH	2 x 600 W	760 W	2100 kg
TR 2000 - 8	2000 AH	2 x 600 W	760W	2250 kg
TR 2000 - 16	2000 AH	2 x 600 W	1520 W	2400 kg
TR 4000 - 16	4000 AH	2 x 600 W	1520 W	3000 kg

### Construction

- Rugged agricultural specification double axle trailer.
- High ground clearance.
- Galvanised steel PV frames.
- IEC Class 2 steel turbine poles.
- Sturdy aluminium internal ZephIR® mounting.

### Deployment

- Electric winches raise and lower turbine poles rapidly.
- Wind up platform raises ZephIR® out of roof hatch.
- Turbine and mast top sections stow inside for transport.
- Trailer can be used as a weather shelter/office.
- 500W AC power sockets for laptops/tools charging.

### Options

- Fuel cell emergency backup rated at 90W continuous, internally mounted and silent.
- 3.5 kVA diesel emergency backup rated at 110A, internally mounted.
- Security GPRS/GPS tracker.



TR1600-8/2000-8

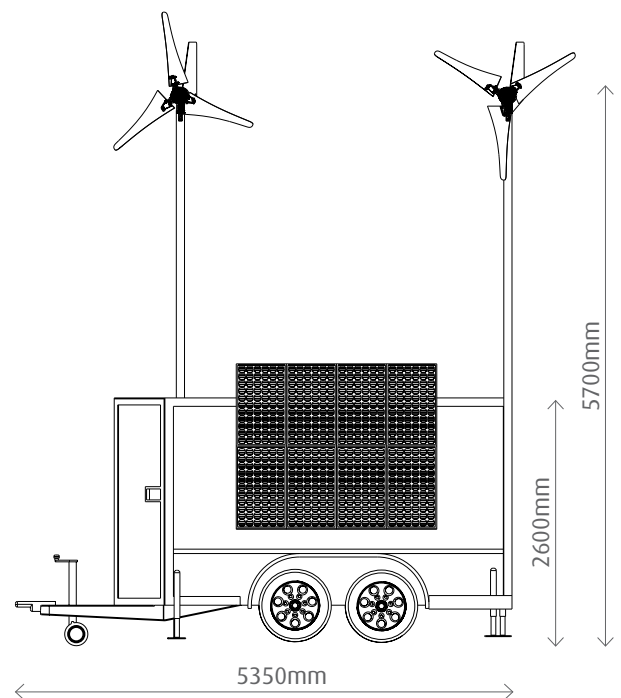

TR2000-16/4000-16

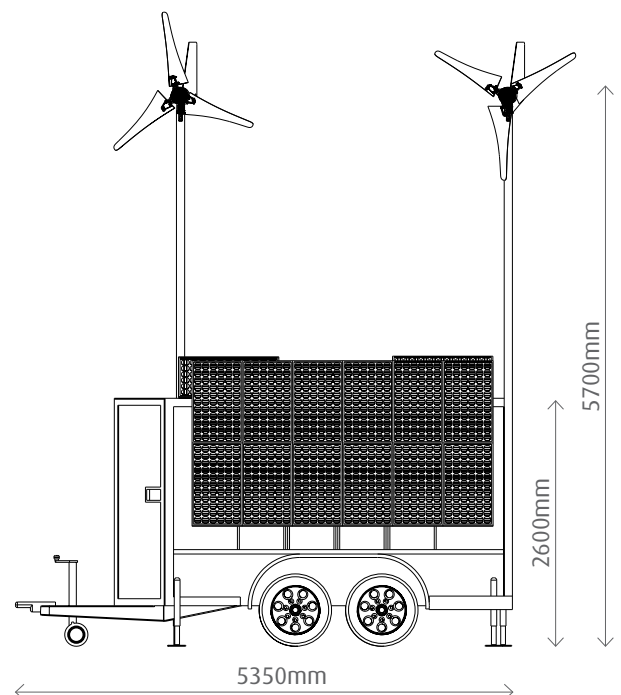

# Offshore Platform

In the offshore environment the Ampair packaged power system comes into its own. With the huge costs of site access a 'fit and forget' power supply is even more desirable.

Ampair provide an offshore version of the heliPod™ system that has removable battery trays and fixed legs. The removable battery trays allow the pods to be lifted and positioned safely by the platforms davit cranes, which are typically rated to only 300kg. The pods are stackable and can be stacked by engineers or by the crane accordingly.

We also offer custom ZephIR® housings which stack on top of the pods to contain the ZephIR® and its washer liquid tank. Ampair can also manufacture a bespoke 'crows nest' solution to incorporate all of your equipment that can be mounted onto offshore structures.

To maximise generation capability from this environment, turbines are a must. Ampair supplies its Ampair 600 turbines with platform mount kits for this purpose.



Image courtesy of Naikun Wind Development Inc.

## Features

- Stackable pallet sized pods.
- Battery trays easily removed for lifting on low capacity davit cranes.
- Custom enclosure for ZephIR® & screen washers.
- Sturdy marine grade powder coated and anodized aluminium construction.
- Ampair 600 turbines supplied on platform mount poles.
- Diesel or fuel cell emergency back up option.

"The Ampair system delivered 100% power availability for two years in average wind speeds of 9.9 m/s"

**Naikun Wind Development Inc**



# High load containerised hybrid units

Ampair have been making bespoke power supplies for remote power applications for nearly 40 years. Whether it be a mobile workshop, refuge or laboratory, we are highly experienced in designing and fitting out containers to meet our customers' requirements.

Ampair also manufacture bespoke larger power systems with power ratings up to 1kW continuous and 6kW sustained for intermittent loads. These are housed in standard 20' or 40' shipping containers fitted with up to ten electrically raised Ampair 600 wind turbines and up to 6kw of solar panels on a

tilt out frame. The units can also be configured as diesel hybrid systems for higher continuous outputs. These systems can also be configured with internal office/workshop or site accommodation to meet your needs.

## Features

- Easily shippable as standard shipping container.
- Marine grade construction.
- Optional diesel hybrid system for higher loads.
- Optional integral workshop/office/accommodation.
- DC, AC single or three phase available.

"At Remote Power Inc. we design and install power systems for commercial, industrial and environmental research applications throughout Alaska. All of our sites experience severe wind and extreme cold. We've tried wind turbines from many different manufacturers but the Ampair turbines are the only ones we're still using. They've been the most reliable at our extreme weather sites and the tech support has been outstanding!"

**Greg Egan, Remote Power, Alaska**

